



Know-how in food processing!



Membrane skinning machines Vliesex

The yield is crucial

Vliesex V 460N • V 560N

Features and application range

- **cutting width:** 430 mm (V 460N)
500 mm (V 560N)
- **cutting speed:** 37 m/min
- **particularly good value membrane skinning machines with high operational speed and very high yield**
- **to remove the membrane from pork, beef, veal, lamb, turkey, game, poultry**
- **industry suited construction**



Spring suspension of blade holder



Transport roller



Photo: Vliesex V 560N

Standard equipment

- **high precision transport roller** without grooves
- **robust precision blade holder**
 - spring suspended for best yield by automatic adjustment to the membrane
 - horizontal position of blade is adjustable, but **cannot be manipulated by the operator without tools**
 - captive screws
 - fine adjustment of blade holder for products with thick membrane (e.g. beef)
- **dynamic (counter rotating) stainless steel cleaning roller** and **NOCK Air Jet compressed air cleaning system** keep the transport roller constantly clean during operation
- adjustable pressure reducer
- boxes for cut membrane can be placed under machine from the front or back
- ergonomic favourable safety foot switch bar, adjustable in height
- 15 mm thick **NOCK POWER PLATES®** installed in the machine casing provide constant precision and service friendliness
- safety switch stops the machine when the processing table is opened
- lockable castors
- stainless steel

Vliesex V 4744 TURBO • V 5744 TURBO

Features and application range

- **cutting width:** 430 mm (V 4744 TURBO)
500 mm (V 5744 TURBO)
- **cutting speed:** 44 m/min
- **high performance membrane skinner for industrial plants with intensive use and highest demands on performance and yield**
- very high cutting speed
- to remove the membrane from pork, beef, veal, lamb, turkey, game, poultry



Standard equipment

- **level processing table so that the product can be fed and removed from all sides**
- **reinforced precision blade holder**
 - spring suspended for best yield by automatic adjustment to the membrane
 - horizontal position of blade is adjustable, but cannot be manipulated by the operator without tools (for models with screws)
 - captive screws
 - **automatic adjustment of blade holder when the machine is started**
 - **blade holder remains in the machine during cleaning (can be turned up)**
- high precision transport roller without grooves
- **dynamic (counter rotating) stainless steel cleaning roller and NOCK Air Jet compressed air cleaning system** keep the transport roller constantly clean during operation
- adjustable pressure reducer
- boxes for cut pieces can be placed under the machine from the front and back
- ergonomic favourable safety foot switch bar, adjustable in height
- 15 mm thick **NOCK POWER PLATES®** installed in the machine casing provide constant precision and service friendliness
- safety switch stops the machine when processing table is opened
- lockable castors
- stainless steel

Option

- blade holder with quick change system

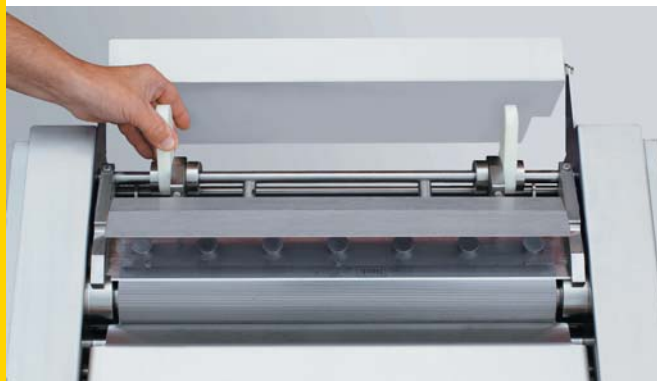

Quick change system for blade

1 Highest attainable yield

As with every processing procedure, the enhancement of the product when membraning must exceed the emerging costs. When the membrane is removed from a product, the highest possible yield, that means a minimum loss of expensive meat, is crucial.

The NOCK membrane skinning machines are highly developed, robust high precision machines **with a yield which is not gradable with technical means:**

- The **transport roller** (blade roller without grooves) is made of high quality, low-wear stainless steel.
- The **blade holder** is a robust precision component; the models Vliesex V 4744 and V 5744 TURBO are equipped with a reinforced version.
- The blade holder is spring suspended, so that it adapts automatically to the thickness of the membrane.
- A fine adjustment of the blade holder (only with Vliesex V 460N and V 560N) for products with a thick membrane (e.g. beef, lamb).
- The blade holder, transport roller and cleaning roller are mounted in the 15 mm thick **NOCK POWER PLATES®**. These plates can be much more exactly manufactured as in comparison to the conventional mountings of the components in the machine casing.
- The blade position cannot be manipulated by the operator once it is set in an optimized horizontal position.

The result: The NOCK membrane skinning machines remove only the bare membrane. **More yield = less cuts cannot be attained.** Of course, when membrane free meat comes into contact with the blade, meat will then be removed instead of any membrane. It depends on the operator and the cut of the meat before membraning.

Tip: For membrane skinning an optimum adjustment of the blade geometry, blade holder and transport roller is essential. This is only guaranteed when processing with original **NOCK TOP H blades**. Other blades (even with nominal corresponding measurements) can cause clearly higher losses.

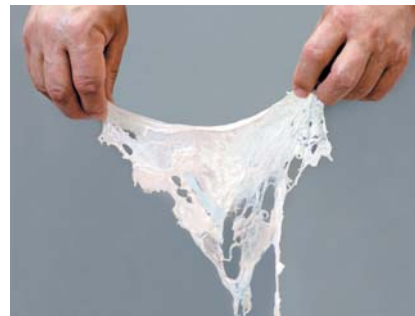

2 Quick and easy processing

A row of important construction features allow quick and easy processing and support the economic efficiency of the NOCK membrane skinning machines:

- High / very high cutting speeds
- The **dynamic (counter rotating) cleaning roller** and the silent **NOCK Air Jet cleaning system** (compressed air cleaning) keep the transport roller constantly clean. Thereby reliable gripping and quick and easy processing are guaranteed. Adjustable pressure reducer. Automatic retraction to processing position when the machine is started.
- Ergonomic favourable **safety foot switch bar, adjustable in height**
- Boxes for cut pieces can be placed under the machine from the front or back (e.g. EURO stacking boxes).
- Left side of the machine has no handles, so that the machine can be placed without any interspace directly beside the cutting table or any other machine.

Additionally available for the models Vliesex V 4744 and V 5744 TURBO:

- **ultra flat processing table** so that the product can be fed and removed from all sides, also longer pieces e.g. pork loins
- automatic (pneumatic) adjustment of blade holder when machine is started

Tip: Membrane skinning machines are not suitable to remove the fat from products, as fat does not have a firm structure. To speed up the membraning process it is recommendable to remove the fat when cutting the meat.



NOCK Air Jet compressed air cleaning system:
Jet bar moved by an enclosed pneumatic cylinder

3 NOCK-typical robustness, reliability and service friendliness

The mechanically highly strained machine parts such as drive, transport roller and blade holder are mounted on the **solid, 15 mm thick base plates**, the **NOCK POWER PLATES®**. These plates are located in the machine casing.

This construction of the NOCK machines, which is proven since 1990, guarantees:

■ Permanent precision

The NOCK POWER PLATES® guarantee an **excellent bearing alignment and constant precise positioning of the machine parts**. This is not attainable with the conventional mounting of these components directly onto the machine casing.

■ No material fatigue

The NOCK POWER PLATES® are with their 15 mm thickness resistant to material fatigue. They make the NOCK membrane skinning machines enormously robust and durable and particularly suitable for several shift industrial continuous operation with intensive machine use.

■ Extraordinary service friendliness

All parts are easily accessible when the side cover is removed.

Every service technician can easily understand the clear and low-service construction of the NOCK machines. A specialist is not required for servicing. **Therefore the NOCK machines are highly appreciated and successfully sold all over the world.**

An enclosed, reliable pneumatic cylinder is installed to move the oscillating jet bar in the NOCK Air Jet cleaning system.

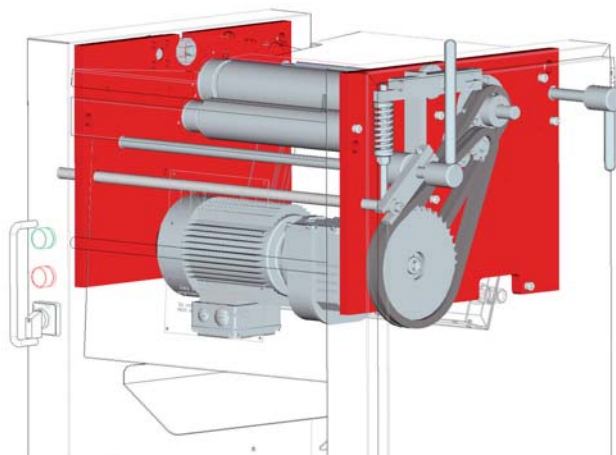

4 Quick cleaning and optimum hygiene

- The NOCK membrane skinning machines have not only a modern, but also **hygienic design**, which naturally complies to the latest hygienic regulations.
- Due to the NOCK POWER PLATES® it is possible to construct the membrane skinning machines with **large smooth surfaces**, which are particularly easy to clean.
- The machine casing, blade holder, transport roller, cleaning roller etc. are made of **high quality stainless steel**.
- All NOCK membrane skinning machines are equipped with lockable **castors** and can be easily transported to the cleaning area.
- The transport roller and cleaning roller can be turned by hand. This way the water spray can reach all sides.

Additional features on the models V 4744 and V 5744 TURBO:

- blade holder remains in the machine during the cleaning procedure (can be turned up)
- quick change system for blade (optional)



5 Top class German machine quality

This begins with the quality orientated concept and construction of the NOCK membrane skinning machines, comprising of the production of all central components at the company-own ultra-modern machine park, the exclusive use of premium base materials and acquired parts, the cooperation with established suppliers, the diligent assembling and final inspection of the machines at NOCK.

6 Fair prices

Thanks to modular construction, modern production methods and strict cost management NOCK is in a position to offer German first class workmanship to very interesting prices.



Technical data + equipment / Membrane skinning machines Vliesex

	Vliesex V 460N	Vliesex V 560N	Vliesex V 4744 TURBO	Vliesex V 5744 TURBO
cutting width (mm)	430	500	430	500
cutting speed (m/min)	37	37	44	44
transport roller without grooves	●	●	●	●
dynamic (counter rotating) stainless steel cleaning roller	●	●	●	●
NOCK Air Jet compressed air cleaning system	●	●	●	●
foot switch adjustable in height	●	●	●	●
spring suspended blade holder	●	●	●	●
quick change system for blades	–	–	○	○
automatic adjustment of blade holder when starting the machine	–	–	●	●
barrier free processing table	–	–	●	●
lockable castors	●	●	●	●
NOCK POWER PLATES®	●	●	●	●
compressed air connection (bar)	5 < p < 10 – quick lock coupling DN 7.2 (G ¹ / ₄ “ external)			
compressed air consumption	approx. 250 l/min (ambient pressure)			
adjustable pressure reducer	●	●	●	●
motor performance (kW)	0.75	0.75	1.1	1.1
electrical connection	3 AC - 400/230 Volt - 50 (60) Hz ^①			
weight (kg)	150	180	170	200
overall dimension W x H x D (mm)	740 x 960 x 630	800 x 960 x 630	740 x 930 x 630	800 x 930 x 630
stainless steel	●	●	●	●
blade dimension (mm)	460 x 20 x 1	520 x 20 x 1	460 x 20 x 1	520 x 20 x 1

① other voltages upon request

● standard

○ optional

NOCK Maschinenbau GmbH
 Industriestrasse 14
 77948 Friesenheim
 GERMANY

Tel: +49 (0) 7821-99 78 16
 Fax: +49 (0) 7821-99 78 18
 E-mail: info@nock-gmbh.com
 www.nock-gmbh.com